

BARRIERS

DEFENDER GUARD RAILS

Defender guard rails are heavy duty steel systems designed for improved protection against 'head-on' collisions as opposed to W-beam guard rails which are primarily designed for deflecting collisions that happen in a near to parallel direction. The system features 140mm diameter, 5mm thick steel wall uprights, and a heavy duty 90mm diameter rail. The guard rail is supplied in component form with all the necessary fixings for assembly. These guard rails can be custom made to suit your application if required.



Specifications:

Material	140mm diameter steel uprights, 5mm wall thickness 90mm diameter steel rails, 5mm wall thickness
Finish	Powdercoated safety yellow
Base plate	250 x 250 x 10mm
In-ground	300mm below ground
Installation	4 x 16mm masonry anchors (bolt-down style) per post

Part No. Style

DGR/BP	Bolt-down post
DGR/IG	In-ground post
DGR2.0	2m long rail
DGR3.0	3m long rail

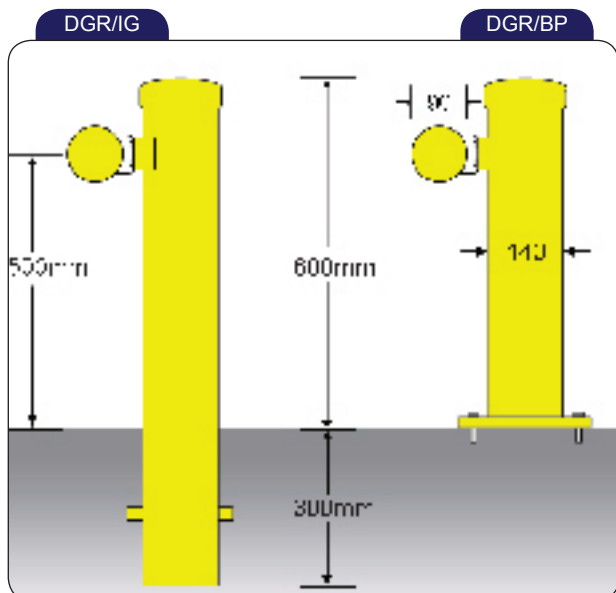

POST AND RAIL BARRIER SYSTEM



Forklifts, cars, trucks and pedestrians just do not mix. Clearly designated pedestrian walkways and warning signs are a start, but for the truly safe workplace, there needs to be a physical barrier between the two. Our post and rail barrier system has been designed to provide protection for pedestrians from a variety of vehicle types.

The system is modular allowing for economical shipping and easy replacement of damaged components. It is easily erected and provides a highly visible barrier. A popular addition to the system is our pallet protection rail, preventing intrusion from wayward pallets.

- Available with a variety of rail lengths,
- Bolt-down or in-ground posts, highly visible yellow finish
- Damaged components replaced easily
- Strong steel protection for pedestrians
- Easy to assemble, shipped in component form to save freight costs
- Optional steel angle for extra protection at ground level (available in a variety of sizes)

Specifications:

Post material	90mm steel pipe
Rail material	115 x 42mm steel tube
Finish	Powdercoated safety yellow
Rail Heights	1010mm top rail 560mm mid rail
Rail lengths	2m, 3m or 6m
Weight	Posts 9kg Rails 4.89kg/m
Installation	4 x M12 masonry anchors per post

Part No. Style

DPR-BP	Base-plated post
DPR-IG	In-ground post
DPR-2	2m rail (set of 2)
DPR-3	3m rail (set of 2)
DPR-6	6m rail (set of 2)
DPR/6KIT	6m rail kit (2 x 6m rails plus 3 x posts)
DPR/3KIT	3m rail kit (2 x 3m rails plus 2 x posts)
DPR/2KIT	2m rail kit (2 x 2m rails plus 2 x posts)
DAPR	Angle protection rail

